



Climbing wall

Ref. KP4012

Last check 07/03/2016

Pag. 1/2

EN-1176-1:2009

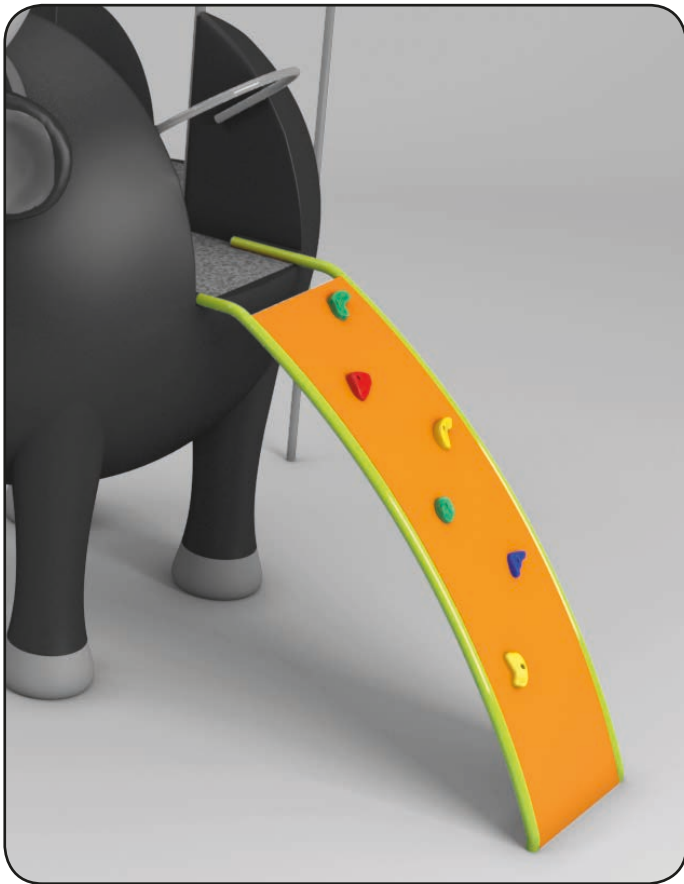

Installation example



ACCESSORIES



Climbing wall

Ref. KP4012

Last check 07/03/2016

Pag. 2/2

EN-1176-1:2009



Technical information.

Materials: Manufactured in Ø40 mm. curved tubular steel. Welded to anchor plate.

Finishes: Baked paint in various colors.

Rocks: Climbing rocks with non-skid finish.

Surface: Curved ramp made in high density polyethylene.

Installation: Anchored to the playground with 4 screws.

Technical data.

Assembly: 2 pers.

Weight: 80 Kg.

Total height: 1,48 m.

Free fall height: 1,50 m.

Dimensions: 1,6 x 0,6 m.

For further information.

Contact us.

KIWI PLAYGROUNDS & WOODS.

C/ Foia, 13 P.I. Alqueria de Moret

46210 Picanya (Valencia)

Tel. +34 963 313 677

E-mail: kiwi@kiwipw.com

Web: www.kiwipw.com

The company reserves its right to apply any modifications or changes to their products.

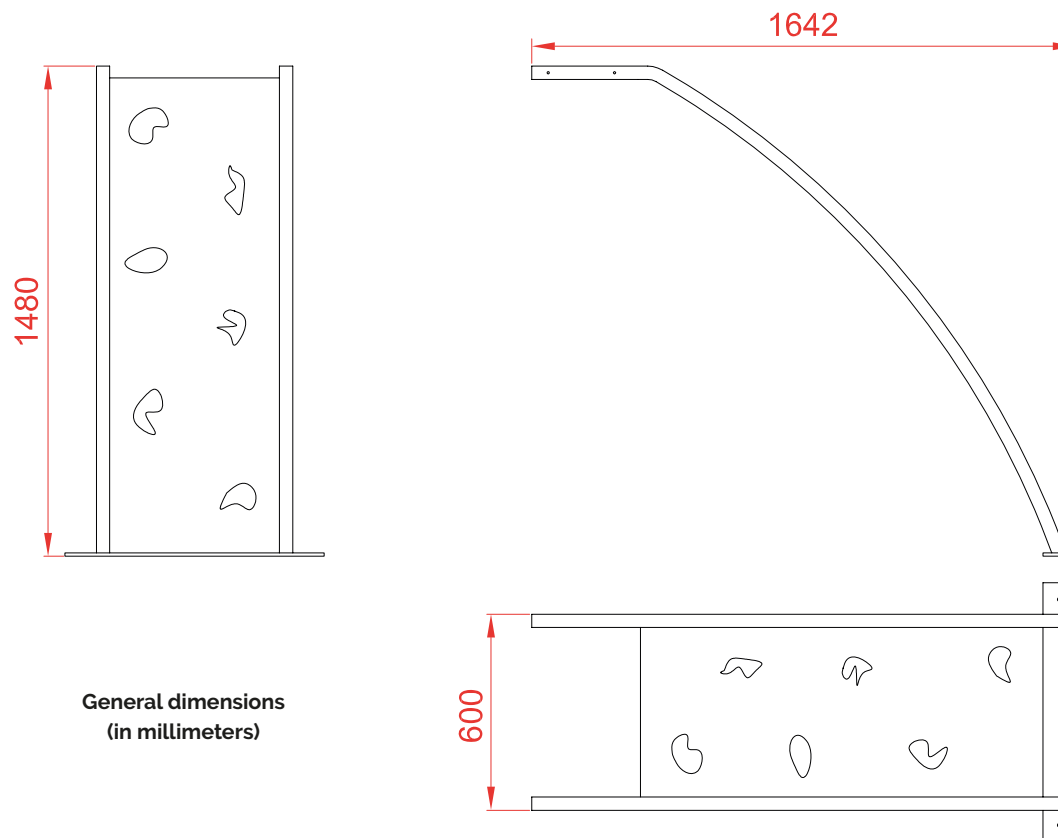

General dimensions
(in millimeters)

Installation.

- Anchoring to the floor with 2 expansion bolts. Finished with compacted material coating either continuous wet-pour rubber surfacing or rubber tiles.

Maintenance.

- Check: All fixing points, screws and bolts must be periodically checked and they will be tightened and adjusted again if necessary. The checking date must be annotated in order to establish a control.

Inspections.

- Routine Inspection: A visual and functional inspection must be carried out every 3 months in order to check that the module has not suffered any harm due to vandalism or mishandling.

- Yearly Inspection: A full inspection of the installation as a whole must be done in order to check that it keeps all norm standards and that it has not suffered any alterations.